

# Muller-Satterthwaite Theorem

## Proof part 2

### Assumption 1: PE

If every voter ranks  $a$  first,  $a$  wins.

### Assumption 2: Monotonicity

If  $a$  is winning, then voters change their preferences so that  $a$  does not drop below any other alternative in any voter's ranking, then  $a$  still wins.

For any alternative  $a$ , there exists an index  $d$  and alternatives  $b$  and  $c$  such that:

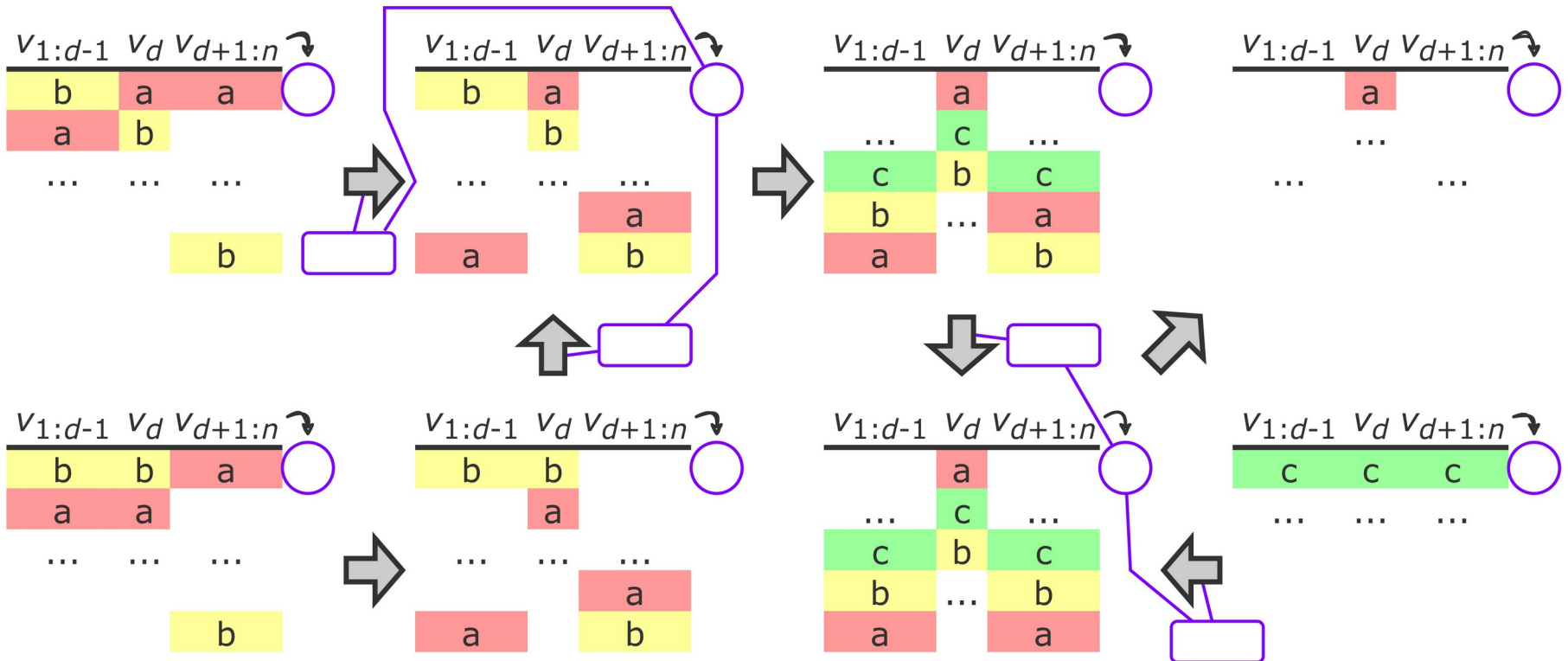

## Arrow's Theorem

### Proof part 2

**Assumption 1: PE**  
 If every voter ranks  $a$  above  $b$ , then society should as well.

**Assumption 2: IIA.**  
 If a voter changes their ranking of alternatives, but does not change the order of  $a$  and  $b$ , then society should still have the same preference over  $a$  and  $b$ .

For any alternative  $a$ , there exists an index  $d$  and alternatives  $b$  and  $c$  such that:

